

Małgorzata GORZEL<sup>1,2\*</sup>, Ryszard KORNIJÓW<sup>3</sup> and Edyta BUCZYŃSKA<sup>4</sup>

## QUALITY OF RIVERS: COMPARISON OF HYDRO-MORPHOLOGICAL, PHYSICAL-CHEMICAL AND BIOLOGICAL METHODS

### STAN EKOLOGICZNY RZEK: PORÓWNANIE METOD HYDROMORFOLOGICZNYCH, FIZYCZNO-CHEMICZNYCH I BIOLOGICZNYCH

**Abstract:** The study was performed in five fourth-order tributaries of the Bystrzyca Lubelska River (Eastern Poland, Lublin Upland), differing in the degree of river-bed transformation and level of pollution. Hydro-morphological methods (descriptive method by Ilnicki and Lewandowski - IL, and index method by Oglecki and Pawlat - OP) and biological indices based on the composition of zoobenthos (Diversity - *D*, and index based on proportions between the density of Oligochaeta and Chironomidae - O/Ch) permitted distinguishing of four classes, from II to V. The distinguishing of only two quality classes (III and IV) was possible by means of physical-chemical methods and by benthic index BMWP\_PL. Those two methods seem to show the lowest sensitivity to the spatial variability of the environment quality. The BMWP\_PL index was the least sensitive to year-to-year environmental changes, and O/Ch was the most sensitive. Relatively high conformity was obtained between hydro-morphological assessments performed by means of the OP and IL methods. Results obtained by means of these tools weakly corresponded with the physical-chemical assessments. The latter assessments were the most similar to those obtained by means of the BMWP\_PL (degree of similarity = 57%) and *D* (47%) indices, and considerably less in the case of O/Ch (36%). The BMWP\_PL and *D* indices better corresponded with the results of the hydro-morphological assessment performed by means of the IL method than with those performed by means of the OP method while *D* index showed a reverse pattern. The O/CH index proved useful for the assessment of the degree of organic pollution of the river's water, but not the sediments.

**Keywords:** river classification, ecological status, hydro-morphology, water chemistry, zoobenthos

## Introduction

The assessment of freshwater resources and quality in the current period of progressing human pressure and water scarcity is a worldwide pressing problem posing a major risk to the global economy and sustainable management [1, 2]. The assessment of quality of

<sup>1</sup> Faculty of Health Sciences, University of Vincent Pol, ul. Choiny 2, 20-816 Lublin, Poland

<sup>2</sup> Research & Science Innovation Centre, ul. Tarasowa 4/96, 20-819 Lublin, Poland

<sup>3</sup> Department of Fisheries Oceanography and Marine Ecology, National Marine Fisheries Research Institute, ul. H. Kołłątaja 1, 81-332 Gdynia, Poland, email: rkornijow@mir.gdynia.pl

<sup>4</sup> Department of Zoology, Animal Ecology and Wildlife Management, University of Life Sciences in Lublin, ul. Akademicka 13, 20-033 Lublin, Poland, email: edyta.buczynska@gmail.com

\* Corresponding author: seminariumgorzel@wp.pl

flowing waters has long been, and in some parts of the world still is [3], based on physical-chemical analyses. It has recently become evident that the assessment of riverine environments requires introducing biological evaluation [4, 5]. Moreover, the determination of the full image of the degradation status of aquatic ecosystems requires the analysis of the hydro-morphological status of river-beds and their riparian zones in order to assess the nature of the habitats and the degree of their transformation/naturalness [6-10]. This is also currently stipulated by the Water Framework Directive (WFD) [11]. As a result of such an approach, it is not the quality of river water that is assessed, but rather the ecological status of the entire river together with its channel and valley.

When the Water Framework Directive was introduced to the European law, it did not specify the tools for the implementation of particular provisions. Pursuant to the assumptions of the document, particular EU member states were expected to develop their own systems of assessment of water quality with the consideration of local environmental and geographical conditions. As a result, a number of publications appeared over the recent years, aiming at the development of river evaluation systems. Works considering all of the three assessment criteria simultaneously, namely the hydro-morphological, physical-chemical, and biological criterion, are still relatively scarce. Moreover, these are usually proposals of assessments [6, 12-21]. Considerably more seldom, they are works aimed at the determination of the sensitivity of methods and the degree of their compatibility and complementarity in the final assessment of a river's ecological state [9, 10, 20, 22], although they can provide information supporting river management decisions [9, 23, 24].

The present contribution is an attempt to fill this gap based on the example of small lowland-upland rivers located in eastern Poland. In the scope of the assessment of the quality of rivers, we compared the sensitivity of two hydro-morphological and three biological methods based on the composition of zoobenthos. We confronted the obtained results with the assessment of water quality performed by means of a routine physical-chemical method. This way, we attempted the assessment of the compatibility of the applied methods. We assumed that the compatibility of assessments performed by means of various methods can be interesting from the theoretical point of view, but it does not have to be the necessary condition of the selection of methods in the water quality monitoring practice. On the contrary, lack of compatibility of results may suggest that various aspects of the structure/functioning of the ecosystem are analysed, increasing the complementarity of the final assessment of the ecological state of a river. This seems to be in accordance with the assumptions of the Water Framework Directive.

## Materials and methods

### Study area

The study was carried out on five small 4th-order rivers: Ciemiega, Czechowka, Czerniejowka, Kosarzewka, and Krenziczanka. They are tributaries of the Bystrzyca Lubelska River, the right tributary of the Wieprz River (Type III according to the Polish classification of catchments; Report on the state 2003) [25] (Fig. 1). They flow through the Lublin Upland, Eastern Poland (51°18'24" N; 22°33'16" E), draining loess soils and Cretaceous rocks.

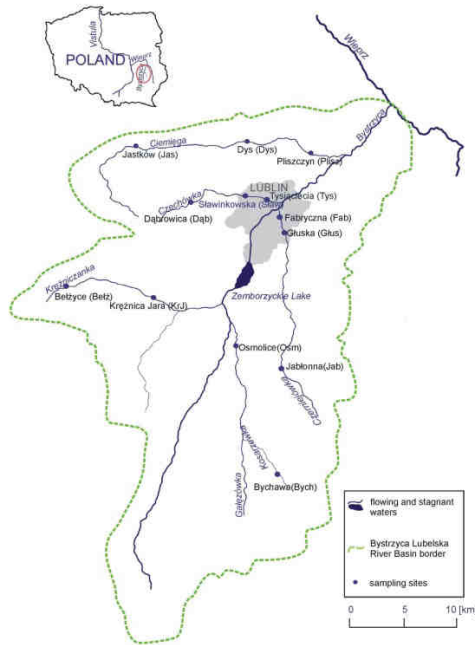

Fig. 1. Sketch map of the Bystrzyca Lubelska River, its water divide, tributaries, and location of sampling sites

The lengths of the studied rivers vary from 17.5 km to 40.5 km, and the areas of their catchments are between 78.5 and 225 km<sup>2</sup>. The mean annual precipitation fluctuates between 550 and 650 mm. The elevation ranges from the sea level up to 300 m.

## Methods

The field research was conducted in 2003 and 2004, three times a year (in spring, summer, and autumn). A total of 13 sampling sites were selected, representing different geo-morphological and hydrological conditions, as well as local settings such as land use, riparian zone management, channel characteristics, and water pollution. Each of the sampling sites represented a typical section of a river with a length of approximately 100 m. The sites were mapped for a variety of physical variables, e.g. substrate types, aquatic and riparian vegetation, erosion or depositional areas, and hydro-technical constructions. At each visit, measurements of the river depth and width, as well as current velocity at the sampling sites were performed. Current velocity ( $V_{\text{surface}}$ ) was determined by the float method [26], according to the following formula:

$$V_{\text{surface}} = \text{travel distance}/(\text{travel time} \cdot k) \quad (1)$$

where  $k$  - a coefficient equal to 0.85 as a commonly used value, taking into account that surface velocities are typically higher than mean or average velocities.

### Hydro-morphological assessment of the river habitat quality

The degree of naturalness/degradation of the investigated river sections was assessed by means of two methods, developed by Oglecki and Pawlat [27], and by Ilnicki and Lewandowski [28]. Further in the paper, the methods are referred to by the corresponding symbols OP and IL. Both of the methods consider the river-bed and its riparian zone (a belt of approximately 20-30 m width along the banks). The parameters assessed in the river-bed assume to reflect the in-stream habitat heterogeneity. They include: water quality (colour, turbidity, and mineral and organic pollution), river channel morphology (the route of the watercourse, shape of the shoreline, slope and shape of banks, embankments, presence of natural obstructions and engineering constructions, and scope and manner of channelization), hydrological parameters (e.g.: changeability of water flow, water depth, and width of the water table), nature of bottom sediments, water and riparian vegetation (species diversity, cover), as well as development of thallophytes, bushes, and woodlots along the banks (composition, age, density, shading). In the riparian zone, the following metrics are evaluated: the degree of naturalness of bank relief, nature of riparian vegetation, and certain characteristics of terrestrial vegetation, e.g. the breast-height diameter of trees. Moreover, the IL method considers land-use in the river valley, and the OP method - the possibility of faunal migrations along the river corridor. In the OP method, points ascribed to particular criteria are multiplied by an appropriate coefficient, depending on the adopted importance of a given criterion for the river's assessment. The IL method treats all of the ecological and landscape parameters equally. It may be concluded that the OP method considers biological characteristics as more important, and the IL method emphasises physical-chemical and morphological characteristics.

In both of the methods, the final classification of river stretches depends on the obtained score. They are classified to particular hydro-morphological (HM) categories: I - near pristine; II - slightly modified; III - moderately modified, in some places channelized; IV - extensively modified, regulated over large stretches; V - heavily transformed or artificial watercourses.

### Physical-chemical assessment

Physical-chemical analyses of the waters were performed in the Voivodship Inspectorate of Environment Protection in Lublin. They involved the determination of the following parameters: physical (water temperature, odour, colour, total suspended matter, and pH), oxygen [dissolved oxygen, organic matter expressed as Biological Oxygen Demand ( $BOD_5$ ) and Chemical Oxygen Demand ( $COD_{Mn}$ ,  $COD_{Cr}$ )], biogenic (ammonia, nitrates, nitrites, total nitrogen, phosphates, and total phosphorus), salinity (electric conductivity, dissolved substances, chlorides, sulphates, calcium, and magnesium), and selected hazardous substances (heavy metals). The analyses were carried out according to the methodology based on international standard methods [29]. In 2003, water physical and chemical properties were analysed at all of the sampling sites, while in 2004, only at those located close to the river mouths.

The status of surface waters was assessed by comparing the monitoring results with the criteria expressed as threshold values of water quality indicators, according to the Regulation of the Polish Ministry of the Environment of 9 November 2011 on the methods of classification of surface water bodies [30]. The classification system is in accordance

with that proposed by WFD. It distinguishes five physical-chemical (PhCh) quality classes: class I - high; class II - good; class III - moderate; class IV - poor; and class V - bad.

### Biological assessment

The assessment was performed based on the analysis of benthic macroinvertebrate communities. Benthos samples were taken by means of a tube sampler with a sampling area of 12.6 cm<sup>2</sup>. Each time five sediment samples were taken from a random location. Each sample consisted of six sediment cores, each 15 cm in length. This number was defined earlier by the evaluation of representativeness of biological material based on the Beklemieszew's criterion [31], determining the relationship between the number of samples taken and the number of taxa found in the samples. The collected sediment was sieved through a net with a mesh size of 0.25 mm, and transferred to plastic containers without water. In the laboratory, each sample was placed on a white tray. The trays were filled with water. Benthic invertebrates longer than 2 mm were collected macroscopically and preserved in 4% formaldehyde solution. The collected macroinvertebrates were identified to the lowest practical taxonomic level according to the appropriate studies [32-34].

The biological assessment of water quality was carried out by means of three indices applied for the assessment of the quality of river waters, two in Poland, and one in the USA:

Index BMWP\_PL was based on the English index BMWP (Biological Monitoring Working Party Score) [35] and adapted by Kownacki et al. [36] for Polish conditions. The index is provided by the following equation:

$$\text{BMWP\_PL} = \sum (n i) \quad (2)$$

where:  $i$  - value of purity class assigned to particular families,  $n$  - number of families in particular classes of water quality.

The BMWP\_PL index categorises rivers into five classes: Class I - very pure waters (BMWP\_PL > 100), Class II - pure waters (BMWP\_PL = 70-99), Class III - slightly polluted waters (BMWP\_PL = 40-69), Class IV - polluted waters (BMWP\_PL = 10-39), and Class V - strongly polluted waters (BMWP\_PL < 10).

The index of biodiversity ( $D$ ) is expressed as follows [36]:

$$D = S/\log N \quad (3)$$

where:  $S$  - number of taxa (families),  $N$  - fauna abundance [ind. m<sup>-2</sup>].

The index of biodiversity ( $D$ ) permits defining five river purity classes: I - very pure waters ( $D > 5.50$ ), II - pure waters ( $D = 4.00-5.49$ ), III - slightly polluted waters ( $D = 2.50-3.99$ ), IV - polluted waters ( $D = 1.00-2.49$ ), V - strongly polluted waters ( $D < 0.99$ ).

The Oligochaeta/Chironomidae index (O/Ch), as a measure of organic pollution [37-39], according to the following formula:

$$\text{O/Ch} = a/b \cdot 100 \quad (3)$$

where:  $a$  - density of Oligochaeta,  $b$  - total density of Oligochaeta and Chironomidae larvae (excluding ubiquitous predatory larvae of *Procladius* sp.).

Based on the results of research by Goodnight [38], the following river purity classes were distinguished: I - very pure waters (O/Ch < 20), II - pure waters (O/Ch = 20-40), III - slightly polluted waters (O/Ch = 39-59), IV - polluted waters (O/Ch = 60-80), Class V - strongly polluted waters (O/Ch > 80).

## Statistical methods

Shapiro-Wilk normality tests preceding one-way ANOVA and Kruskal-Wallis tests performed in Statistica 10.0 software were conducted to detect potential significant differences between dominating taxa of the studied tributaries. To determine the general character of relationships between three biological indices (BMWP\_PL, *D*, O/Ch) and different environmental variables of different types, we selected 19 representative parameters (environmental, physical, oxygen and biogenic) for the multivariate ordination analyses. Changes to river bed were given as the degree of regulation (1 - semi-natural courses with very high natural values, 2 - courses relatively poorly transformed, with high natural values, 3 - moderately valuable courses, with regulated stretches, 4 - low natural values, some fragments of the course with clearly transformed ecosystems, 5 - rivers stretches completely regulated, natural values very low). Organic matter and substrates were provided at five-degree scales. The lowest amount of organic matter corresponded with the first degree, the highest amount, respectively, with the fifth degree. Substrates were coded as follow: 1 - fine sand, 2 - medium sand, 3 - coarse sand, 4 - fine and medium sand with pebbles, 5 - medium to coarse sand with pebbles. At first we performed the method of Detrended Correspondence Analysis (DCA) in order to assess the range of the environmental gradient. Since it was lower than 2 SD (Standard Deviation) units, we chose Redundancy Analysis (RDA) [40]. No transformations were applied to data matrix as well as no collinearities between variables were found. To test the significance of the environmental variables ( $P < 0.05$ ), forward selection (FS) was used with the Monte Carlo permutation test. All multivariate statistics were performed in CANOCO 4.5 for Windows [41]. Finally, to compare the results obtained by six different methods (IL, OP, PhCh, BMWP\_PL, *D*, O/Ch) we performed the cluster analysis (UPGMA) with the use of PAST 3.05 program [42]. This procedure, widely used in similar studies [43, 44], allowed to distinguish the most important similarities between different approaches to water quality assessment. The strength of Spearman's correlations used as supporting methods was determined as follows: 0.0-.19 "very weak" • .20-.39 "weak" • .40-.59 "moderate" • .60-.79 "strong" • .80-1.0 "very strong".

## Results

### Hydro-morphological assessment

#### *Physical features of riverine habitats*

The width and mean depth of the rivers studied varied substantially over the study period, although the values generally did not exceed 7 and 0.6 m, respectively (Table 1). Current velocity fluctuated between 0.02 and 0.45 m/s, also with strongly marked temporal changes. The mean values were generally higher in the lower sections of the rivers, regardless of the extent of channel modification. The channel morphology of the six sections of the rivers (Dys, Plisz, Jab, Bych, Osm, and KrJ) was close to the natural state. The remaining ones, mostly located in urban areas, were modified by means of channelization and engineering works to a varying degree. The bottom substrates were mostly mineral, and composed of sand and gravel. Submerged vegetation occurred in the majority of the sections (Fig. 2, Table 1). The vegetation near the banks in the sections located in rural areas (e.g., Dys, Plisz, Jab, and KrJ) was varied, composed of herbaceous plants, single trees, and shrubs (Fig. 2). These river sections were usually distinguished by

considerable shading (30-75%) caused by crowns of trees growing on the banks (Table 1). Vegetation near the banks along the urban sections was usually composed exclusively of herbaceous plants, with occasional single trees. In such cases, the water surface was strongly exposed to solar radiation (sites: Slaw, Tys, Glus, Fab, and Belz).

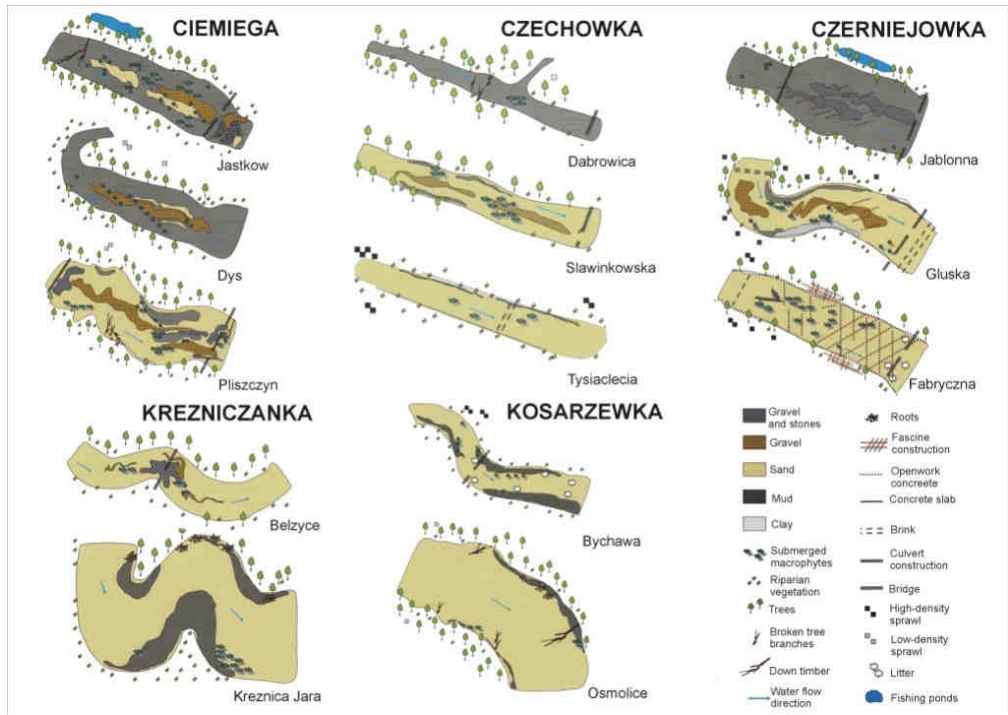

Fig. 2. Conceptual aerial sketch of the studied section showing their hydro-morphological features and topography. For more characteristics of the sites see Table 1

Environmental characteristics of the studied river sections

Table 1

River	Location	Site code	Mean width [m]	Mean depth [m]	Current velocity [m/s]	Man-induced changes to river-bed
Ciemiega (Ciem)	Jastkow Village	Jas	3.8 3.5-4.0	0.4 0.3-0.6	0.30 0.18-0.43	straightened channel
	Dys Village	Dys	5.0 3.5-5.5	0.6 0.5-0.7	0.27 0.25-0.33	none
	Pliszczyn Village	Plisz	4.9 4.5-5.7	0.5 0.4-0.6	0.45 0.36-0.58	none
Czechowka (Czech)	Dabrowica Village	Dab	1.6 1.0-2.5	0.2 0.2-0.3	0.18 0.15-0.22	straightened channel
	Lublin City, Slawinkows-ka Str.	Slaw	2.0 1.0-2.5	0.3 0.2-0.4	0.39 0.27-0.58	straightened channel
	Lublin City, Tysiaclecia Str.	Tys	2.4 2.0-3.5	0.3 0.3-0.3	0.34 0.20-0.45	straightened, trapezoidal concrete channel

River	Location	Site code	Mean width [m]	Mean depth [m]	Current velocity [m/s]	Man-induced changes to river-bed
Czerniejowka (Czern)	Jablonna Village	Jab	7.3 7.0-7.5	0.5 0.5-0.6	0.02 0.02-0.03	none
	Lublin City, Głuska Str.	Glus	4.0 3.5-4.7	0.6 0.5-0.7	0.30 0.10-0.37	trapezoidal, meandering channel, artificial rapids
	Lublin City, Fabryczna Str.	Fab	3.4 3.3-3.6	0.3 0.3-0.3	0.34 0.18-0.41	straightened channel
Krezniczanka (Krez)	Belzyce Town	Belz	2.7 2.5-3.0	0.4 0.3-0.5	0.27 0.17-0.32	straightened channel
	Kreznica Jara Village	KrJ	7.5 7.0-8.0	0.4 0.4-0.5	0.31 0.25-0.35	none
Koszarzewka (Kos)	Bychawa Town	Bych	1.7 1.5-2.0	0.2 0.2-0.3	0.29 0.25-0.37	none
	Osmolice Village	Osm	6.5 6.0-7.0	0.6 0.6-0.6	0.27 0.20-0.33	none

River	Land use	Sediment	Macro-phytes	Riparian vegetation	Canopy cover [%]
Ciemiega (Ciem)	meadows, arable fields	gravel and sand	regular and dense patches of <i>Sparganium emersum</i> , <i>Callitriche verna</i>	single trees, herbaceous plants	11-50
	meadows	gravel and sand	sporadic and sparse patches of <i>C. verna</i>	single trees, herbaceous plants	31-75
	meadows, arable fields	gravel and sand	regular and dense patches <i>Ranunculus aquatilis</i> , <i>C. verna</i>	trees, shrub, herbaceous plants	31-75
Czechowka (Czech)	meadows, arable fields	silt	sporadic and sparse patches of <i>Veronica beccabunga</i>	single trees, herbaceous plants	11-75
	urban areas	sand	dense and irregular patches of <i>Elodea canadensis</i> , <i>Ceratophyllum demersum</i>	herbaceous plants	0-30
	urban areas	sand	no vegetation	herbaceous plants	0
Czerniejowka (Czern)	meadows	silt and mud	sporadic, sparse patches of <i>C. verna</i>	single trees, herbaceous plants	31-75
	urban areas	gravel, sand and silt	regular, dense patches of <i>Potamogeton gramineum</i> , <i>P. pectinatus</i> , <i>E. canadensis</i> , <i>C. demersum</i>	herbaceous plants	0-30
	urban areas	Sand	regular, sparse patches of <i>P. crispus</i> , <i>Zannichela palustris</i>	herbaceous plants	0-30
Krezniczanka (Krez)	urban areas	sand	regular and dense patches of <i>C. verna</i> , <i>Sparganium erectum</i> , <i>Nasturtium officinale</i>	herbaceous plants	0
	meadows, forest	sand	sporadic and sparse patches of <i>E. canadensis</i>	trees, shrubs, herbaceous plants	31-75
Koszarzewka (Kos)	urban areas	sand	no vegetation	herbaceous plants	11-50
	meadows, arable fields	sand and silt	irregular and dense patches of <i>E. canadensis</i>	trees, herbaceous plants	11-75



## Evaluation of the river sections

Both of the methods applied, OP and IL, provided very consistent results (Fig. 3). They permitted distinguishing the same number of four hydro-morphological (HM) categories among the river sections, from HM category II (slightly modified) to V (heavily transformed). The differences only concerned two river sections (Jas and Bych). In the former case, a higher, and in the latter, a lower degree of naturalness was determined, with a difference of one category.

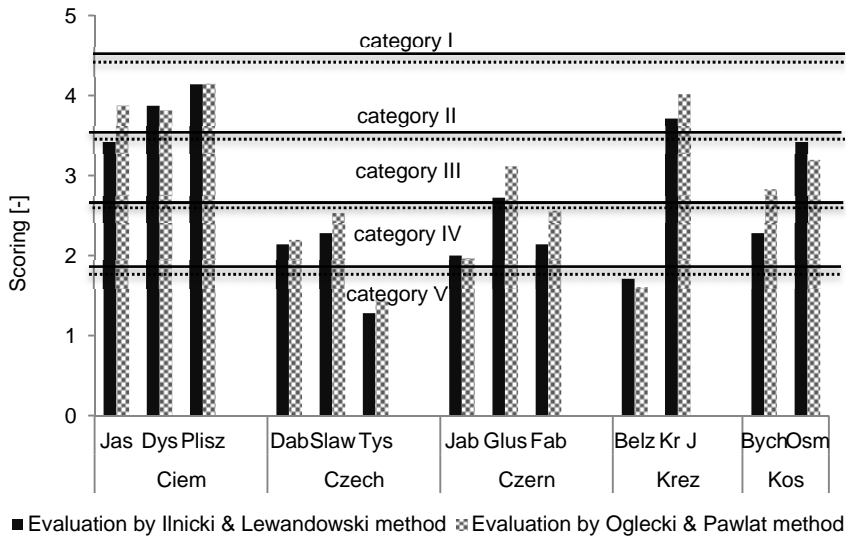

Fig. 3. Hydro-morphological evaluation of the river sections by means of two methods: Ilnicki and Lewandowski [28] and Oglecki and Pawlat [27]. For the sites code look at Table 1. Categories: I - near pristine; II - slightly modified; III - moderately modified; IV - extensively modified; V - heavily transformed

## Physical-chemical assessment

### Physical-chemical water quality

The majority of physical and salinity indices, and those suggesting high content of organic matter (BOD<sub>5</sub>, ammonia, and total nitrogen), usually showed increased values on river sections flowing through urbanised areas (the Czerniejowka, Krezniczanka, and Czechowka rivers, with the exception of site Dab). The values were usually considerably higher than in the waters of the Ciemiega and Kosarzewka Rivers, mainly flowing through agricultural areas (Tables 2 and 3).

The Ciemiega River was also distinguished by relatively low concentrations of biogene indices. An interesting pattern was observed in the case of magnesium. Its concentrations, irrespective of the manner of management of the river valley and hydro-morphological category, were two or three times higher in the Ciemiega and Czechowka Rivers than in the remaining ones (Table 2).

Table 2

River water properties in terms of physical, oxygen, and biogenic indicators. Means and ranges for 2003 and 2004

Indicators	Tributaries	Ciemiega			Czechowka			
	Sites	Jas	Dys	Plisz	Dab	Sław	Tys	
Physical	pH [-]	8.00-8.37 8.13	8.08-8.49 8.24	8.07-8.45 8.20	7.67-8.35 7.73	8.24-8.41 8.31	7.78-8.31 8.52	
	Suspended matter [mg dm <sup>-3</sup> ]	5-13 9.7	3-14 9.0	3-12 6.15	2-52 19.7	13-53 33.0	7-40 26.1	
Oxygen	Dissolved oxygen [mg O <sub>2</sub> dm <sup>-3</sup> ]	4.3-10.7 7.9	7.6-10.9 9.5	8.8-12.2 10.5	7.2-11.8 8.9	3.5-12.9 9.3	7.8-11.9 10.0	
	BOD <sub>5</sub> [mg O <sub>2</sub> dm <sup>-3</sup> ]	2.0-5.6 3.2	2.3-1.0 1.7	0.7-2.1 1.4	0.9-2.1 1.6	3.3-6.3 5.1	2.2-9.5 6.1	
Biogenic	Total nitrogen [mg N dm <sup>-3</sup> ]	1.24-1.47 1.4	1.5-1.9 1.7	2.0-2.7 2.4	3.4-4.4 4.0	2.3-2.9 2.6	1.8-3.8 2.8	
	Ammonia [mg NH <sub>4</sub> dm <sup>-3</sup> ]	0.36-0.60 0.48	0.18-0.56 0.33	0.06-0.38 0.21	0.07-0.26 0.15	0.26-0.82 0.48	0.06-1.13 0.66	
	Nitrites [mg NO <sub>2</sub> dm <sup>-3</sup> ]	0.13-0.02 0.05	0.02-0.06 0.04	0.01-0.03 0.02	0.03-0.04 0.03	0.04-0.37 0.15	0.04-0.20 0.12	
	Nitrates [mg NO <sub>3</sub> dm <sup>-3</sup> ]	0.84-1.81 1.32	2.12-2.43 2.29	5.87-6.77 6.29	11.00-15.33 13.39	1.54-6.01 3.93	2.60-7.24 4.77	
	Total phosphorus [mg P dm <sup>-3</sup> ]	0.09-0.28 0.13	0.11-0.18 0.15	0.11-0.24 0.15	0.18-0.22 0.19	0.22-0.29 0.23	0.25-0.52 0.40	
	Phosphates [mg PO <sub>4</sub> dm <sup>-3</sup> ]	0.07-0.22 0.12	0.11-0.39 0.23	0.16-0.40 0.28	0.30-0.47 0.41	0.03-0.59 0.22	0.15-0.72 0.39	
Indicators	Tributaries	Czerniejowka			Krezniczanka		Kosarzewka	
	Sites	Jab	Glus	Fab	Belz	KrJ	Bych	Osm
Physical	pH [-]	7.54-8.36 7.93	7.91-8.31 8.14	7.95-8.41 8.15	7.84-7.90 7.90	7.74-8.18 8.0	7.90-8.20 8.01	7.67-8.18 7.95
	Suspended matter [mg dm <sup>-3</sup> ]	3-69 25.0	9-51 27.7	6-166 44.8	4-12 8.7	3-14 8.2	4-92 33.3	4-12 8.5
Oxygen	Dissolved oxygen [mg O <sub>2</sub> dm <sup>-3</sup> ]	6.9-13.5 9.7	7.5-14.3 6.9	6.6-14.6 10.0	7.7-10.1 9.2	8.2-12.3 10.0	9.9-13.5 11.1	7.5-10.6 8.7
	BOD <sub>5</sub> [mg O <sub>2</sub> dm <sup>-3</sup> ]	1.0-2.1 1.6	2.3-4.1 3.4	2.1-10 4.7	2.3-4.9 3.2	1.9-4.4 3.2	1.5-2.3 2.0	1.8-4.4 2.8
Biogenic	Total nitrogen [mg N dm <sup>-3</sup> ]	4.2-4.3 4.3	2.3-3.1 2.7	1.5-3.2 2.5	3.7-6.1 4.9	1.9-4.9 3.4	3.6-4.3 3.9	2.9-4.0 3.5
	Ammonia [mg NH <sub>4</sub> dm <sup>-3</sup> ]	0.06-0.27 0.13	0.13-0.30 0.18	0.06-0.93 0.40	0.04-0.19 0.12	0.12-0.30 0.16	0.04-0.08 0.06	0.38-0.82 0.55
	Nitrites [mg NO <sub>2</sub> dm <sup>-3</sup> ]	0.04-0.07 0.05	0.03-0.08 0.06	0.04-0.11 0.37	0.03-0.17 0.08	0.06-0.12 0.10	0.03-0.04 0.03	0.06-0.20 0.12
	Nitrates [mg NO <sub>3</sub> dm <sup>-3</sup> ]	14.00-15.24 14.71	4.11-7.86 5.79	3.00-8.08 4.99	12.68-23.50 23.02	4.02-15.16 10.56	14.10-17.10 14.85	8.44-12.11 9.70
	Total phosphorus [mg P dm <sup>-3</sup> ]	0.14-0.19 0.15	0.12-0.23 0.16	0.12-0.36 0.22	0.08-0.13 0.10	0.15-0.61 0.20	0.08-0.25 0.14	0.17-0.4 0.25
	Phosphates [mg PO <sub>4</sub> dm <sup>-3</sup> ]	0.32-0.39 0.35	0.06-0.39 0.18	0.07-0.47 0.27	0.03-0.28 0.16	0.28-1.11 0.69	0.17-0.26 0.23	0.29-0.80 0.55

Table 3

River water properties in terms of salinity indicators and hazardous substances.  
Means and ranges for 2003 and 2004

Indicators	Tributaries	Ciemiega			Czechowka		
	Sites	Jas	Dys	Plisz	Dab	Slaw	Tys
Salinity indicators	Electric conductivity [ $\mu\text{S cm}^{-1}$ ]	658-816 731	593-674 635	538-640 588	522-729 652	584-646 616	553-1799 858
	Dissolved substances [ $\text{mg dm}^{-3}$ ]	342-435 394	350-422 390	368-426 392	436-459 450	315-388 358	356-743 485
	Chlorides [ $\text{mg Cl dm}^{-3}$ ]	11.7-14.0 12.8	8.9-13.1 11.1	11.4-17.6 14.2	14.4-26.6 20.2	18.6-25.4 21.5	12.8-64.4 33.1
	Sulphates [ $\text{mg SO}_4 \text{ dm}^{-3}$ ]	4.1-15.7 10.4	13.7-18.2 15.6	13.5-36.7 19.9	23.0-28.7 26.0	21.0-31.7 26.3	17.9-64.1 35.1
	Calcium [ $\text{mg Ca dm}^{-3}$ ]	98.4-127.0 114.5	98.3-109.0 105.4	95.1-106.0 102.0	101.0-112.0 108.3	72.7-92.5 85.2	78.6-120.0 91.5
	Magnesium [ $\text{mg Mg dm}^{-3}$ ]	16.5-18.7 17.9	16.4-19.2 17.6	16.5-18.7 17.5	6.5-20.6 15.9	16.3-18.3 17.4	12.4-23.2 18.1
	Hazardous substances	Copper [ $\text{mg Cu dm}^{-3}$ ]	< 0.004	< 0.004	< 0.004-0.006	< 0.004	< 0.004
Lead [ $\text{mg Pb dm}^{-3}$ ]		< 0.005	< 0.005	< 0.005	< 0.005	< 0.005	< 0.005
Total iron [ $\text{mg Fe dm}^{-3}$ ]		0.515-0.955 0.725	0.176-1.040 0.480	0.004-0.444 0.120	0.044-0.853 0.317	0.208-0.689 0.524	0.008-1.440 0.470

Indicators	Tributaries	Czerniejowka			Krezniczanka		Kosarzewka	
	Sites	Jab	Glus	Fab	Belz	KrJ	Bych	Osm
Salinity indicators	Electric conductivity [ $\mu\text{S cm}^{-1}$ ]	553-566 557	460-524 496	27-1220 612	662-685 659	536-599 563	553-556 552	514-588 444
	Dissolved substances [ $\text{mg dm}^{-3}$ ]	355-373 364	282-336 312	292-1000 438	443-464 450	355-464 497	352-399 370	338-373 362
	Chlorides [ $\text{mg Cl dm}^{-3}$ ]	18.9-21.3 19.7	14.2-18.4 16.0	11.4-355.0 74.4	22.5-30.0 25.3	16.5-27.9 24.2	14.7-19.8 16.7	8.9-18.3 14.1
	Sulphates [ $\text{mg SO}_4 \text{ dm}^{-3}$ ]	22.6-26.3 24.1	20.7-27.3 24.1	20.1-51.3 27.7	66.3-78.0 71.3	33.3-58.3 44.4	18.3-23.5 20.1	14.9-21.2 17.4
	Calcium [ $\text{mg Ca dm}^{-3}$ ]	101.0-105.0 102.7	91.4-98.0 91.5	68.7-99.1 86.6	95.0-131.0 115.7	94.5-122.0 102.9	103.0-106.0 101.3	94.4-102.0 97.7
	Magnesium [ $\text{mg Mg dm}^{-3}$ ]	5.3-5.7 5.5	5.6-5.9 5.8	4.1-6.7 5.8	2.9-3.2 3.1	2.6-5.7 5.0	6.7-7.2 6.9	7.1-8.2 7.6
	Hazardous substances	Copper [ $\text{mg Cu dm}^{-3}$ ]	< 0.004	< 0.004	< 0.004-0.110	< 0.004	< 0.004	< 0.004
Lead [ $\text{mg Pb dm}^{-3}$ ]		< 0.005	< 0.005	< 0.005	< 0.005	< 0.005	< 0.005	< 0.005
Total iron [ $\text{mg Fe dm}^{-3}$ ]		0.025-0.088 0.054	0.071-0.416 0.230	0.013-0.288 0.120	0.015-0.269 0.110	0.005-0.139 0.050	0.04-0.056 0.050	0.004-0.097 0.038

### Physical-chemical classification

Good water quality was only suggested by the physical indices and content of heavy metals. This was recorded on a total of four river sections (Table 4). The remaining indices usually suggested lower water quality. The final assessment permitted distinguishing two

physical-chemical (PhCh) water quality classes: the most frequently occurring moderate water quality (PhCh class III), and poor water quality (PhCh class IV), usually found in urban river sections (Tys and Fab). In the second year of the study, only one section (Fab) obtained a different, worse water quality assessment.

Table 4  
Physical-chemical evaluation of river waters in 2003 and 2004 (where available), respectively

River	Site code	Physical indicators	Oxygen indicators	Biogenic indicators	Salinity indicators	Hazardous substances	Final evaluation
Ciemiega	Jas	III	IV	III	III	III	III
	Dys	III	III	III	III	IV	III
	Plisz	III, III	III, III	III, II	III, III	III, III	III, III
Czechowka	Dab	IV	II	III	III	III	III
	Slaw	IV	V	III	III	III	IV
	Tys	V, III	IV, IV	IV, III	III, III	IV, II	IV, IV
Czerniejowka	Jab	IV	II	III	III	II	III
	Glus	IV	III	III	II	III	III
	Fab	V, IV	III, V	III, III	II, IV	II, I	III, IV
Krezniczanka	Belz	I	III	III	III	II	III
	KrJ	II, III	III, III	IV, V	III, III	II, I	III, III
Kosarzewka	Bych	III	II	III	II	I	III
	Osm	II, III	III, IV	III, IV	II, III	I, I	III III

## Biological assessment

### *Richness, composition, and density of benthic invertebrates*

The zoobenthos included a total of 194 taxa of various ranks, particularly species and genera (Table 5). The lowest numbers of taxa were recorded at the strongly regulated (EM category V) and the most polluted (PhCh quality class IV) site Tys, located in Lublin on the Czechowka River. The upper and lower sections of the Ciemiega River (Jas and Plisz) belonging to EM category II, and the middle section of the Czerniejowka River (Glus) included in EM category III were the richest in taxa. Their waters were categorised to PhCh class III.

The lowest mean densities of bottom fauna were found in the Krezniczanka River section KrJ of high EM category (II), with water of moderate quality (PhCh class III). The highest densities were recorded at the heavily transformed (EM category V) urban sites: Tys (26044 ind./m<sup>2</sup>) and Belz (14450 ind./m<sup>2</sup>), carrying waters of the PhCh class IV and III, respectively.

The mean zoobenthos density in specific river sections varied strongly, and their values showed a trend reverse to species richness (Table 5).

The faunal communities in all of the studied river sections were always dominated by Tubificinae and Chironomidae, irrespective of the hydro-morphological status or water quality (Table 5).

As for the sum of taxa as well as their total and particular densities of dominating taxa (Table 5) some significant differences were found between tributaries except for Hydrachnidia ( $p = 0.034$ ). Among all taxa included in Table 5 only *Gammaridae* ( $rs = -0.73$ ) and the genus *Pisidium* ( $rs = -0.61$ ) showed negative statistically important correlations with final, physico-chemical evaluation of the water quality. Gammaridae also showed negative correlation ( $rs = -0.67$ ) with salinity indicators while *Pisidium* showed the

same ( $r_s = -0.77$ ) for physical indicators. In turn, two trichopteran families Lepidostomatidae and Hydropsychidae correlated with other indices: the first family demonstrated moderate negative correlation ( $r_s = -0.56$ ) with classes obtained with the use of biogenic indicators, while the second family reached strong positive correlation with hazardous substances ( $r_s = 0.74$ ).

Table 5

Total taxa, total mean density, and densities of dominant taxa [ind. m<sup>-2</sup>] of zoobenthos in the tributaries of the Bystrzyca Lubelska River. Values for the period 2003-2004. For sites abbreviations see Table 1

Tributaries sites	Ciemiega			Czechowka			Czerniejowka			Krezniczanka		Kosarzewka	
	Jas	Dys	Plisz	Dab	Slaw	Tys	Jab	Glus	Fab	Bych	Osm	Belz	KrJ
Number of taxa	87	58	72	37	55	29	44	88	43	48	58	56	57
Total density	5805	6225	7892	9317	4846	26044	7106	6680	8756	6590	7843	14450	4381
Tubificinae	1967	4358	3611	5657	2664	16355	359	943	7063	2695	1525	10061	1216
Chironomidae	1227	1657	1672	2987	1084	8741	5671	3550	714	2700	2824	2574	80
Gammaridae	263	451	345	338	0	0	76	391	45	5565	1330	55	90
Pisidium sp.	725	464	698	18	73	5	237	163	186	160	8620	1282	4085
Sphaerium sp.	454	72	5	9	81	5	0	170	334	20	42	25	134
Sialidae	182	93	0	35	0	0	363	31	0	5	0	0	4
Lepidostomatidae	0	0	367	0	0	0	0	0	0	0	0	0	0
Hydropsychidae	90	30	118	0	5	5	0	184	0	0	0	0	0
Limoniidae	135	34	278	75	104	0	15	315	0	199	64	281	56
Hydrachnidia	49	32	37	4	4	0	104	365	87	15	27	5	59

### Assessment by means of macroinvertebrate indices

The biological evaluation of water quality based on the BMWP\_PI index permitted distinguishing two water quality classes: III (moderate) and IV (poor) (Fig. 4). The lowest index values were determined for section Tys (EM category V, PhCh class IV), and the highest values for sections located on the Ciemiega River (predominantly EM category II and PhCh class III). A different assessment was obtained in the following years for three river sections. In two of them (Glus, Osm), better water quality was recorded, and in one (Fab) - worse.

The application of the index of biodiversity D permitted distinguishing 4 water quality classes, from II (good) to V (bad) (Fig. 5). In both of the study years, the highest assessment was determined for the weakly hydro-morphologically transformed (HM category II according to OP method; HM category III according to IL method), section Jas with waters of PhCh class III, and section Glus (HM category III by both methods; PhCh class III). The lowest index values, similarly as in the case of the BMWP\_PL index, were recorded in the hydro-morphologically degraded section Tys (Lublin, the Czechowka River). In the second study year, five of the river sections changed their classification. In three cases the classification improved, and in one case, it deteriorated.

The assessment of water quality performed based on the Oligochaeta/Chironomidae (O/Ch) index showed the differentiation of water quality corresponding to four classes, from II to V (Fig. 6). Similarly as in the case of the D index, the O/Ch index showed the lowest water quality on section Fab (HM category IV; PhCh class III-IV). These were all of the similarities between the classifications. According to the O/Ch index, the best conditions occurred in the Czerniejowka River on sections Jab and Glus, and somewhat worse on both of the sections of the Kosarzewka River and one of the Krezniczanka

River (KrJ). These sections reached only HM category III or IV, and PhCh class between III and IV.

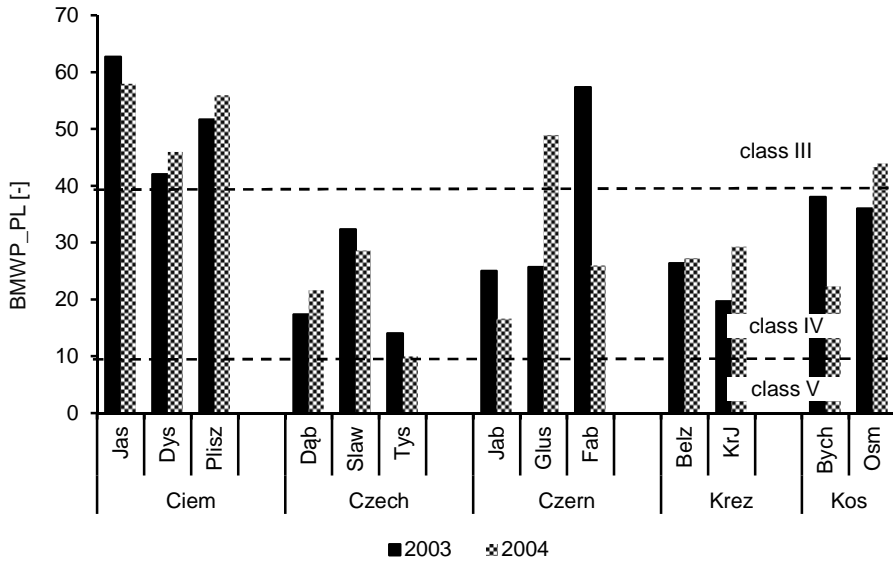

Fig. 4. Biological assessment of water quality in the Bystrzyca Lubelska River's tributaries based on the BMWP\_PL index in 2003 and 2004. For sites abbreviations see Table 1

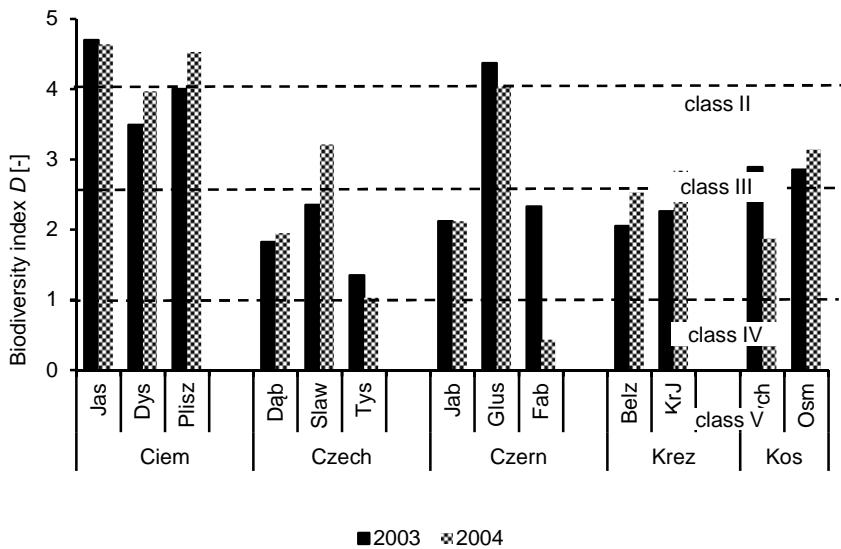

Fig. 5. Biological assessment of water quality in the Bystrzyca Lubelska River's tributaries based on the D index in 2003 and 2004. For sites abbreviations see Table 1

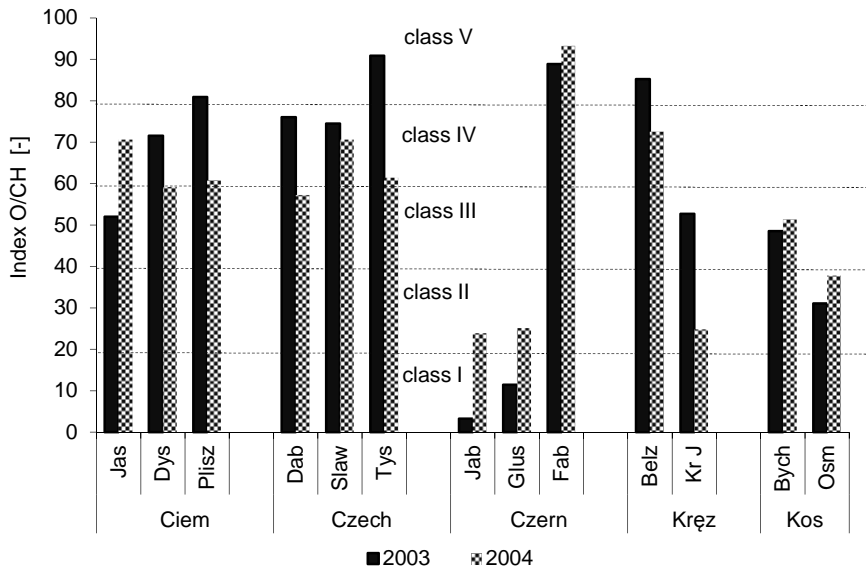

Fig. 6. Biological assessment of water quality in the Bystrzyca Lubelska River's tributaries based on the O/Ch index in 2003 and 2004. For sites abbreviations see Table 1

In the second year of the study, as many as eight sections were assessed differently. In five cases the assessment improved, and in two cases it deteriorated. These were usually differences of one class, and in one case of 2 classes (site KrJ).

The task of the index was to determine the degree of water pollution with organic substances suggested by the BOD<sub>5</sub> index. A rather weak, but statistically significant correlation was indeed determined between the values of the O/Ch and BOD<sub>5</sub> indices ( $r = 0.308816$ ;  $p = 0.05$ ;  $n = 54$ ).

The results of the RDA analysis (Fig. 7) showed that among 19 selected parameters only three were statistically significant: substratum (conditional importance  $\lambda_a = 0.17$ ,  $F = 6.56$ ,  $P = 0.004$ ), the degree of river regulation (conditional importance  $\lambda_a = 0.13$ ,  $F = 5.16$ ,  $P = 0.016$ ) and the content of organic matter (conditional importance  $\lambda_a = 0.07$ ,  $F = 63.15$ ,  $P = 0.034$ ). All environmental variables used explained 70% of the total variance of the indices. The biplot (Fig. 7) represented 65% of the variance in the data. Along the gradient of the first axis the highest correlation was found for substratum ( $r_s = -0.5$ ), in case of the second axis this score was observed for the content of organic matter ( $r_s = -0.38$ ). Among three significant variables, organic matter and substratum were almost fully correlated ( $r_s = 0.91$ ). *D* index showed the strongest relationship towards substratum and organic matter since all vectors are placed in the same biplot quarter. BMWP\_PL is in clear opposition to the degree of river regulation: its highest values were obtained for the sites with lower impact of man-induced changes. O/Ch index was spatially separated from the remaining indices. Worth mentioning is the fact that it was related the most with BOD<sub>5</sub> and pH, however, those variables were not statistically important.

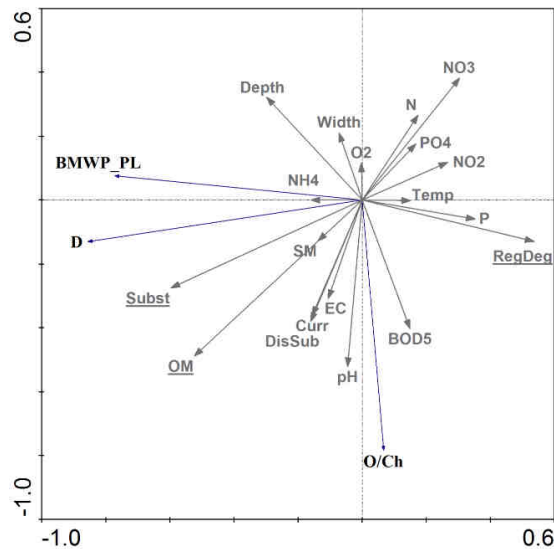

Fig. 7. The RDA biplot showing relationships between three biological indices (BMWP\_PL, D and O/Ch) and 19 selected environmental variables. Abbreviations: Width - river width, Depth - river depth, Curr - current velocity, Subst - substratum, OM - organic matter, RegDeg - the degree of river regulation, Temp - temperature, O<sub>2</sub> - dissolved oxygen, BOD<sub>5</sub> - biochemical oxygen demand, pH, SM - suspended matter, NH<sub>4</sub> - ammonia, NO<sub>3</sub> - nitrates, NO<sub>2</sub> - nitrites, N - total nitrogen, PO<sub>4</sub> - phosphates, P - total phosphorus, DisSub - dissolved substances, EC - electric conductivity. Underlined parameters were statistically significant

### Sensitivity and compatibility of the indices

The evaluation of the sensitivity of the applied methods of assessment of environment quality can be performed by taking into consideration the responses of indices to both the differences in environmental conditions between sites, and temporal changes occurring at the same sites (Table 6).

Table 6  
Assessment of the rivers sections by means of the hydro-morphological, physical-chemical, and biological methods in 2003 and 2004 (if available), respectively

River	Site	Hydro-morphological		Physical-chemical	Biological		
		OP	IL		BMWP_PL	D	O/Ch
Ciemiega	Jas	II	III	III	III, III	II, II	III, IV
	Dys	II	II	III	III, III	III, III	IV, III
	Plisz	II	II	III, III	III, III	III, II	V, IV
Czechowka	Dab	IV	IV	III	IV, IV	IV, IV	IV, III
	Slaw	IV	IV	IV	IV, IV	IV, III	IV, IV
	Tys	V	V	IV, IV	IV, IV	IV, IV	V, IV
Czerniejowka	Jab	IV	IV	III	IV, IV	IV, IV	I, II
	Glus	III	III	III	IV, III	II, II	I, II
	Fab	IV	IV	III, IV	III, IV	IV, V	V, V
Krezniczanka	Belz	V	V	III	IV, IV	IV, III	V, IV
	KrJ	II	II	III, III	IV, IV	IV, III	III, II
Kosarzewka	Bych	III	IV	III	IV, IV	III, IV	III, III
	Osm	III	III	III, III	IV, III	III, III	II, II



The hydro-morphological methods showed a wide range of environmental variability on particular river sections, covering four HM categories, from II to V. The same range of variability of environmental values was suggested by the biological indices D and O/Ch.

The lowest sensitivity to the spatial variability of environment quality seemed to occur in the case of physical-chemical methods and the BMWP\_PL index (Table 6). Each of the methods permitted distinguishing only two quality classes (III and IV).

The weakest response to year-to-year environmental changes again occurred in the case of the BMWP\_PL index, and the strongest in the case of the O/Ch index (Table 6).

The degree of similarity of results obtained by means of particular methods, expressed as percent contribution of river sections qualified to the same classes, is presented in Table 7.

Table 7  
Compatibility of the methods of river quality assessment, expressed as percent contribution of sites with the same quality class based on the comparison of particular indices

Index	IL	PhCh	BMWP_PL	D	O/Ch
OP	81	35	38	51	36
IL		35	54	43	33
PhCh			57	47	36
BMWP_PL				58	27
D					23

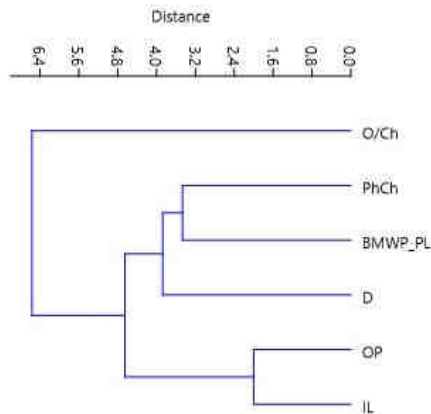

Fig. 8. Linkages between the methods of river quality assessment provided with the method of unweighted pair-group average (UPGMA) (Euclidean distances)

Notice the relatively high conformity of hydro-morphological assessments performed by means of the OP and IL methods. The same results are given in Figure 8, which shows in details interconnections between all six methods. OP and IL create clearly distinguished group with highest similarity. Results obtained by means of such methods correspond relatively weakly with the physical-chemical assessments (degree of similarity = 35%). Assessments performed by means of the physical-chemical method are the most similar to the results obtained by means of the biological indices BMWP\_PL (57% accordance) and D (47%), and considerably less in the case of O/Ch (36%). In Figure 8 first three methods form the second homogenous group, while the last biological index is even strongly

separated from the remaining methods which also corresponds with the Figure 7. The BMWP\_PL index corresponds better with the results of the hydro-morphological assessment performed by means of the IL method than by the OP method. The *D* index showed a reverse pattern.

## Discussion

Both of the hydro-morphological methods applied in the study provided comparable results (Table 7). However, both of the methods are somewhat inconsistent. Similarly as other methods, e.g. the River Habitat Survey, they use criteria of physical-chemical quality of water. It is a useful criterion, although it is broader than the requirements imposed by WFD [45]. The hydro-morphological assessment of sections of Lublin rivers weakly corresponded with the results of the physical-chemical assessment (Table 2). Irrespective of the adopted hydro-morphological method, only in 35% of the analysed cases, hydro-morphological assessments were in accordance with the physical-chemical assessment (Tables 6 and 7).

Results of assessments of rivers performed by means of hydro-morphological methods developed by Oglecki and Pawlat and by Ilnicki and Lewandowski have not been so far confronted with results based on benthic indices. Meanwhile, it is believed that the hydro-morphological status of rivers can play a considerable role in shaping the structure of benthic macroinvertebrate communities [6, 46-48]. River regulation leads to habitat impairment through scouring, sedimentation, habitat homogenization, and altered riparian vegetation, resulting in the loss of taxa of narrow ecological requirements [49-52]. The studied case showed a high similarity of assessments performed by means of the hydro-morphological IL method and biological index BMWP\_PL, and by the hydro-morphological OP method and the *D* index. Higher values of the indices were generally recorded in near-natural sections than in regulated and transformed ones which was demonstrated the best by RDA analysis. The comparison of the three benthic indices applied in this study, namely BMWP\_PL, *D*, and O/Ch, evidences the usefulness of the two former ones. Their advantage is relatively high complementarity in relation to hydro-morphological as well as physical-chemical methods. The *D* index permitted distinguishing twice as many water quality classes as BMWP\_PL. Therefore, it seems to be more sensitive to changes occurring in the river environment.

Benthic indices BMWP\_PL and *D*, and particularly the former one, turned out highly complementary also with the physical-chemical methods. This is in accordance with the observation that benthic invertebrates respond to changes in water pollution [53-55]. According to Raczynska et al. [56], the concordance of physical-chemical and biological assessments may occur exclusively in extremely polluted or very clean rivers. This, however, seems to depend on the selection and sensitivity of the applied benthic indices.

The benthic index O/Ch was earlier applied in the assessment of the degree of pollution of river waters with organic substances in the USA [37, 38, 10]. In the case of the rivers of Lublin, results obtained by means of the index weakly corresponded with results obtained by means of the other two benthic indices discussed above. This is justified, because the O/Ch index is expected to provide specific information, namely that concerning the degree of pollution of a river with organic matter. This type of pollution is usually related to certain water cleanliness parameters, such as e.g. BOD<sub>5</sub> [57] which corresponded with the results of RDA analysis. Therefore, a positive correlation could be expected

between the O/Ch values and concentrations of the parameter. Such a correlation did occur. No significant correlation was determined, however, between the O/Ch index values and the content of organic matter in the sediments. This could have resulted from the mosaic character of the bottom habitat. In rivers, in a relatively small space, the process of elution can occur simultaneously with sediment accumulation. As a consequence, its composition in rivers shows exceptional spatial and temporal variability. Due to this, the applicability of the O/Ch index for the assessment of river sediments is doubtful. An opposite situation occurs in the profundal of lakes, where the O/Ch index is successfully applied in the assessment of the trophic status [34]. The conditions there, however, are strongly unified in terms of space, and relatively stable in time. Much promising in this respect for rivers is *D* index whose clear relationships to sediments were obtained by our results.

The study results may be helpful for the continuously conducted works on the development of benthic indices in Poland. They confirm the necessity of simultaneous application of biological methods as well as physical-chemical and hydro-morphological analyses for the comprehensive determination of the ecological status of rivers. In many cases, their results do not correspond with each other, but are supplementary to each other.

## Conclusions

When assessing river environments, the Water Framework Directive (WFD) requires not only physico-chemical analyses of water/sediments (the only applied method for decades), but also the evaluation of biota and analysis of the hydro-morphological status of river-beds and their riparian zones. This stimulated new studies aiming at the development of river evaluation methods. Publications considering all the three assessment criteria simultaneously, however, are still scarce. In this paper we examined the reliability and compatibility of three evaluations required by WFD: the degree of river-bed transformation (descriptive method by Ilnicki and Lewandowski - IL, and index method by Oglecki and Pawlat - OP), analyses of zoobenthos (its diversity - *D*, proportions between the density of Oligochaeta and Chironomidae - O/Ch, and BMWP\_PL index), and physical-chemical water properties. The study was performed on five fourth-order upland rivers (Eastern Poland).

The study results may be helpful for the continuously conducted works on the development of benthic indices in Poland. They confirm the necessity of simultaneous application of biological methods as well as physical-chemical and hydro-morphological analyses for the comprehensive determination of the ecological status of rivers. In many cases, their results do not correspond with each other, but are supplementary to each other.

Hydro-morphological methods (both IL, and OP) and biological indices (*D* and O/Ch) permitted the designation of four classes, from II to V. Physical-chemical methods and benthic index BMWP\_PL allowed for the designation of only two quality classes (III and IV). The latter two methods seem to show the lowest sensitivity to the spatial variability of environment quality. The BMWP\_PL index was also the least sensitive to year-to-year environmental changes, while O/Ch was the most sensitive. Results obtained by means of the OP and IL methods weakly corresponded with the physical-chemical assessments. The latter assessments were the most similar to those obtained by means of the BMWP\_PL and *D* indices, and considerably less in the case of O/Ch. The BMWP\_PL and *D* indices corresponded better with the results of the hydro-morphological assessment performed by means of the IL method than with those performed by means of the OP method while *D*

index showed a reverse pattern. The O/CH index proved useful for the assessment of the degree of organic pollution of the river's water, but not the sediments.

The study confirms the necessity of simultaneous application of biological methods as well as physical-chemical and hydro-morphological analyses for the determination of the ecological status of rivers. They provide various but complementary information that together comprehensively characterise the state of the riverine environment.

## References

- [1] Du Plessis A, Global Water Scarcity and Possible Conflicts Freshwater Challenges of South Africa and Its Upper Vaal River: Current State and Outlook. Springer Water. 2017; 45-62. <http://www.springer.com/gp/book/9783319495019>.
- [2] McDonald RIP, Green D, Balk BM, Fekete C, Revenga M, Montgomery TM. Urban growth, climate change, and freshwater availability. *P Natl Acad Sci USA*. 2011;108(15):6312-6317. DOI: 10.1073/pnas.1011615108.
- [3] Srebotnjak T, Carr G, de Sherbinin A, Rickwood C. A global Water Quality Index and hot-deck imputation of missing data. *Ecol Indic*. 2012; 17:108-119. DOI:10.1016/j.ecolind.2011.04.023.
- [4] Turley MD, Bilotta GS, Extence CA, Brazier RE. Evaluation of a fine sediment biomonitoring tool across a wide range of temperate rivers and streams. *Freshwater Biol*. 2014;59(11):2268-2277 DOI: 10.1111/fwb.12429.
- [5] Nichols SJ, Barmuta LA, Chessman BC, Davies PE, Dyer FJ, Harrison ET, et al. The imperative need for nationally coordinated bioassessment of rivers and streams. *Mar Freshwater Res*. 2017;68(4):599-613. DOI: 10.1071/mf15329.
- [6] Beavan L, Sadler J, Pinder L. The invertebrate fauna of a physically modified urban river. *Hydrobiologia*. 2001;445:97-108. DOI: 10.1023/a:1017584105641.
- [7] Tavzes B, Urbanic G, Toman MJ. Biological and hydromorphological integrity of the small urban stream. *Phys Chem Earth*. 2006;31:1062-1074. DOI:10.1016/j.pce.2006.07.009.
- [8] Sandin L. The relationship between land-use, hydromorphology and river biota at different spatial and temporal scales: a synthesis of seven case studies. *Fund Appl Limnol*. 2009;174:1-5. DOI: 10.1127/1863-9135/2009/0174-0001.
- [9] Fan JT, Semenzin E, Meng W, Giubilato E, Zhang Y, Critto. et al. Ecological status classification of the Taizi River Basin, China: a comparison of integrated risk assessment approaches. *Environ Sci Pollut Res*. 2015;22(19):14738-14754. DOI: 10.1007/s11356-015-4629-x.
- [10] Miserendino M, Kutschker A, Brand C, La Manna L, Di Prinzio C, Papazian G, et al. Ecological status of a Patagonian mountain river: Usefulness of environmental and biotic metrics for rehabilitation assessment. *Environ Manage*. 2016;57(6):1166-1187. DOI: 10.1007/s00267-016-0688-0.
- [11] Directive 2000/60/EC of The European Parliament and of The Council of 23 Oct. 2000 establishing a framework for Community action in the field of water policy (WFD). Official J Europ Communities L 327/1, 2000. [http://ec.europa.eu/environment/water/water-framework/index\\_en.html](http://ec.europa.eu/environment/water/water-framework/index_en.html).
- [12] Duffy BT, George SD, Baldigo BP, Smith AJ. Assessing condition of macroinvertebrate communities and bed sediment toxicity in the Rochester Embayment Area of Concern, New York, USA. *J Great Lakes Res*. 2017; 43(5):890-898. DOI:10.1016/j.jglr.2017.02.002.
- [13] Hoekstra AY, Chapagain AK, van Oel PR. Advancing Water Footprint Assessment research: Challenges in monitoring progress towards Sustainable Development Goal 6. *Water-Sui*. 2017;9(6). DOI: 10.3390/w9060438.
- [14] Szoszkiewicz KS, Jusik, I, Lewin I, Czerniawska-Kusza J, Kupiec M, Szostak M. Macrophyte and macroinvertebrate patterns in unimpacted mountain rivers of two European ecoregions. *Hydrobiologia*. 2018;808(1):327-342. DOI: 10.1007/s10750-017-3435-5.
- [15] Heatherly TII, Whiles MR, Royer TV, David MB. Relationships between water quality, habitat quality, and macroinvertebrate assemblages in Illinois streams. *J Environ Qual*. 2007;36:1653-1660. DOI: 10.2134/jeq2006.0521.
- [16] Verdonschot PFM. Impact of hydromorphology and spatial scale on macroinvertebrate assemblage composition in streams. *Integr Environ Assess Manage*. 2009;5:97-109. DOI: 10.1897/IEAM\_2008-028.1.
- [17] Timm H, Kairo K, Mols T, Virro T. An index to assess hydromorphological quality of Estonian surface waters based on macroinvertebrate taxonomic composition. *Limnologia*. 2011;41:398-410. DOI: 10.1016/j.limno.2011.09.006.

- [18] Cortelezzi A, Sierra MV, Gomez N, Marinelli C, Capitulo AR. Macrophytes, epipelic biofilm, and invertebrates as biotic indicators of physical habitat degradation of lowland streams (Argentina). *Environ Monit Assess.* 2013;185:5801-5815. DOI: 10.1007/s10661-012-2985-2.
- [19] Urbanic G. Hydromorphological degradation impact on benthic invertebrates in large rivers in Slovenia. *Hydrobiologia.* 2014;729:191-207. DOI: 10.1007/s10750-012-1430-4.
- [20] Błachuta J, Szoszkiewicz K, Gebler D, Schneider SC. How do environmental parameters relate to macroinvertebrate metrics? Prospects for river water quality assessment. *Pol J Ecol.* 2014;62:111-122. DOI: 10.3161/104.062.0111.
- [21] Rajfur M, Kłos A. Use of algae in active biomonitoring of surface waters. *Ecol Chem Eng S.* 2014;21(4):561-576. DOI: 10.1515/eces-2014-0040.
- [22] Bis B, Zdanowicz A, Zalewski M. Effects of catchment properties on hydrochemistry, habitat complexity and invertebrate community structure in a lowland river. *Hydrobiologia.* 2000;422/423:369-387. DOI: 10.1023/A:1017002923173.
- [23] Pistocchi A, Udias A, Grizzetti B, Gelati E, Koundouri P, Ludwig R, et al. An integrated assessment framework for the analysis of multiple pressures in aquatic ecosystems and the appraisal of management options. *Sci Total Environ.* 2017;575:1477-1488. DOI: 10.1016/j.scitotenv.2016.10.020.
- [24] Valero E, Alvarez X, Picos J. An assessment of river habitat quality as an indicator of conservation status. A case study in the Northwest of Spain. *Ecol Indic.* 2015;57:131-138. DOI: 10.1016/j.ecolind.2015.04.032.
- [25] Raport o stanie środowiska województwa lubelskiego w 2003 roku. [Report on the state of the environment of Lublin Voivodship in 2003]. Lublin: Biblioteka Monitoringu Środowiska; 2004. <http://www.wios.lublin.pl/srodowisko/raporty-o-stanie-srodowiska/>.
- [26] Hooper FF, Kohler SL. Measurement of stream velocity and discharge. Chapter 19. In: Schneider JC, editor. *Manual of Fisheries Survey Methods II: With Periodic Updates.* Michigan Department of Natural Resources, Fisheries Special Report 25, Ann Arbor; 2000; 1-5. [http://www.michigan.gov/documents/dnr/SMII\\_Assembled\\_Doc\\_2017\\_final\\_552610\\_7.pdf](http://www.michigan.gov/documents/dnr/SMII_Assembled_Doc_2017_final_552610_7.pdf).
- [27] Oglęcki P, Pawlat H. The index method of small lowland river environmental evaluation. *Annals of Warsaw Agriculture University. SGGW, Land Reclamation,* 2000;30:37-43.
- [28] Ilnicki P, Lewandowski P. Ekomorfologiczna waloryzacja dróg wodnych Wielkopolski. [Ecomorphological evaluation of waterways in Wielkopolska]. *Akademia Rolnicza w Poznaniu;* 1997; 128. ISBN: 8390860503, 9788390860503.
- [29] Hermanowicz W, Dożańska W, Dojlido J, Kozirowski B. Fizyczno-chemiczne badanie wody i ścieków. [Physical-chemical investigations of water and sewage]. Warszawa: Arkady Press; 1999; 848. ISBN: 9788321340678.
- [30] Rozporządzenie Ministra Środowiska z dnia 9 listopada 2011 r. w sprawie sposobu klasyfikacji stanu jednolitych części wód powierzchniowych oraz środowiskowych norm jakości dla substancji priorytetowych. [Regulation of the Polish Ministry of the Environment of 9 November 2011. on the methods of classification of surface waters and environmental quality standards for priority substances]. *Dziennik Ustaw* Nr 257, poz. 1545. [isap.sejm.gov.pl/Download?id=WDU20112571545&type=2](http://isap.sejm.gov.pl/Download?id=WDU20112571545&type=2).
- [31] Montusiewicz M, Chomczyńska J, Malicki J, Łągód G. Biofilm sampling for bioindication of municipal wastewater treatment. In: Pawłowski L, Dudzińska MR, Pawłowski A. editor. *Environmental Engineering III.* London: CRC Press; 2010; 491-496. ISBN: 9780415548823.
- [32] Quigley M. *Invertebrates of Stream and Rivers.* Edward Arnold, London, 1977. ISBN-13: 978-0713100914.
- [33] Cranston PS. A key to the larvae of the British Orthocladinae (Chironomidae). *Freshwater Biological Association Scientific Publication;* 1982; 152. DOI: 10.1002/iroh.19830680229.
- [34] Wiederholm T. Chironomidae of the Holarctic region. Keys and diagnoses. Part 1, Larvae. *Entomol Scand. Supplement* 19;1983.
- [35] Extence CA, Bates AJ, Forbes WJ, Barham PJ. Biologically based water quality management. *Environ Pollut.* 1987;45:221-236. DOI: 10.1016/0269-7491(87)90059-5.
- [36] Kownacki A, Soszka H, Fleituch T, Kudelska D. The ecological assessment of river quality in Poland on the basis of communities of benthic invertebrates. In: Kownacki A, Soszka H, Fleituch T, Kudelska D, editors. *River Biomonitoring and Benthic Invertebrate Communities.* Warszawa-Kraków: Institute of Environmental Protection; 2002; 71-88. ISBN: 8385444904.
- [37] King D, Ball RC. A quantitative biological measure of stream pollution. *J Water Pollut Control Fed.* 1964;36:650-653. <http://www.jstor.org/stable/25035074>.
- [38] Goodnight C. Use of aquatic macroinvertebrates as indicators of stream pollution. *T Am Microsc Soc.* 1973;92:1-13. DOI: 10.2307/3225166.
- [39] Wiederholm T. Use of benthos in lake monitoring. *J Wat Poll Control.* 1980;52:537-547. <http://www.jstor.org/stable/25040750>.

- [40] Ter Braak CJF, Smilauer P. CANOCO reference manual and CanoDraw for Windows User's Guide: Software for Canonical Community Ordination (version 4.5.). Microcomputer Power, Ithaca, NY, 2002. www. <http://edepot.wur.nl/405659>.
- [41] Ter Braak CJF. Canonical community ordination. Part I: Basic theory and linear methods. *Ecoscience*. 1994;1(2):127-140. DOI: 10.1080/11956860.1994.11682237.
- [42] Hammer Ę, Harper DAT, Ryan PD. PAST: Paleontological statistics software package for education and data analysis. *Palaeontol Electron*. 2001;4(1):9pp. [http://palaeo-electronica.org/2001\\_1/past/issue1\\_01.htm](http://palaeo-electronica.org/2001_1/past/issue1_01.htm); 2001.
- [43] Łagód G, Chomczyńska M, Montusiewicz A, Malicki J, Bieganski A. Proposal of measurement and visualization methods for dominance structures in the saprobe communities. *Ecol Chem Eng S*. 2009;16(3):369-377. [http://tchic.uni.opole.pl/freeECE/S\\_16\\_3/LagodChomczynska\\_16\(3\).pdf](http://tchic.uni.opole.pl/freeECE/S_16_3/LagodChomczynska_16(3).pdf).
- [44] Łagód G, Chomczyńska M, Montusiewicz A, Malicki J, Stransky D. Methods applied for measurement and visualization of changes in biodiversity. *Ecol Chem Eng S*. 2014;21(4):593-604. DOI: 10.1515/eces-2014-0042.
- [45] Grzybowski M, Endler Z. Hydro-morphological evaluation of the Łyna River along the Kotowo-Ardapy section. *Quaest Geograph*. 2012;31(1):51-65. DOI: 10.2478/v10117-012-0008-6.
- [46] Buffagni A, Erba S, Cazzola M, Kemp JL. The AQEM multimetric system for the southern Italian Apennines: assessing the impact of water quality and habitat degradation on pool macroinvertebrates in Mediterranean rivers. *Hydrobiologia*. 2004;516:313-329. DOI: 10.1023/B:HYDR.0000025273.15958.6a.
- [47] Hering D, Moog O, Sandin L, Verdonschot PFM. Overview and application of the AQEM assessment system. *Hydrobiologia*. 2004;516:1-20. DOI: 10.1023/B:HYDR.0000025255.70009.a5.
- [48] Lorenz A, Hering D, Feld CK, Rolauffs P. A new method for assessing the impact of morphological degradation on the benthic invertebrate fauna for streams in Germany. *Hydrobiologia*. 2004;516:107-127. DOI: 10.1023/B:HYDR.0000025261.79761.b3.
- [49] Gorzel M, Kornijów R. The response of zoobenthos to "natural channelization" of a small river. *Ecohydrol Hydrobiol*. 2007;7:261-272. [www.sciencedirect.com/science/article/pii/S1642359307701891](http://www.sciencedirect.com/science/article/pii/S1642359307701891).
- [50] Koperski P. Reduced diversity and stability of chironomid assemblages (Chironomidae, Diptera) as the effect of moderate stream degradation. *Pol J Ecol*. 2009;57:125-138. [aeu.miiz.waw.pl/pliki/article/ar57\\_1\\_10.pdf](http://aeu.miiz.waw.pl/pliki/article/ar57_1_10.pdf).
- [51] Wyzga B, Oglęcki P, Radecki-Pawlik A, Skalski T, Zawiejska J. Hydromorphological complexity as a driver of the diversity of benthic invertebrate communities in the Czarny Dunajec River, Polish Carpathians. *Hydrobiologia*. 2012;696:29-46. DOI: 10.1007/s10750-012-1180-3.
- [52] Ji ZG. *Hydrodynamics and Water Quality: Modeling Rivers, Lakes, and Estuaries*. 2<sup>nd</sup> edition. New Jersey: John Wiley Sons; 2017. ISBN: 978-1-118-87715-9.
- [53] De Pauw N, Ghetti PE, Manzani P, Spaggiari R. Biological assessment methods for running water. In: Newman P, Piavaux NA, Sweeting RA, editors. *River Water Quality. Ecological Assessment and Control*. Brussels: Commission of the European Communities; 1992:217-248.
- [54] Rosenberg DM, Resh VH. *Freshwater Biomonitoring and Benthic Macroinvertebrates*. New York: Chapman and Hall, 1993. ISBN 0412022516. DOI: 10.2307/1467358.
- [55] Fleituch T, Soszka H, Kudelska D, Kownacki A. Macroinvertebrates as indicators of water quality in rivers: a scientific basis for Polish standard method. *Large Rivers*. 2002;13:225-239. DOI: 10.1127/lr/13/2002/225.
- [56] Raczyńska M, Żurawska J, Chojnacki JC. The problem of quality assessment of surface lotic waters as exemplified by rivers Tywa and Rurzyca. *EJPAU*. 2000;3:1-17. <http://www.ejpau.media.pl/volume3/issue1/fisheries/art-03.html>.
- [57] Hynes HBN. *The Biology of Polluted Waters*. Liverpool: Liverpool University Press;1960; 202. DOI: 10.1002/iroh.19610460321.